



SERVICE BULLETIN

N° SB 001 – Md3

- INFORMATION
- RECOMMENDED

✓ **MANDATORY**

Date 30/06/2016

SUBJECT: Md3 Rider FUEL GAUGE “Skoda 120”

SCOPE: after analyzing the causes of an accident involving a Rider in Lithuania it was determined that one of the fuel gauge sensors for automotive origin (Skoda 120) had given causing the fuel spill that has invaded the cockpit during the flight, forcing the pilots a forced landing fortunately successfully without injury.

Given the great hazard event the component must be replaced with another of proven reliability.

MODELS AFFECTED: All MD3 Rider products that mount that component products from FLY ITALIA and GRYF Aircraft Sro

TIME OF COMPLIANCE: Within next flight

MANPOWER: 10 man-hour

REQUIRED MATERIAL: New kit (KIT n° SB001-Md3) and related installation instructions.

TOOLING: special tools are required

WEIGHT AND BALANCE : Nil

REFERENCES: Md3-10-000LP

PUBLICATIONS AFFECTED: Nil

For further information, please contact Next Aircraft at E-mail airworthiness@next-aircraft.com

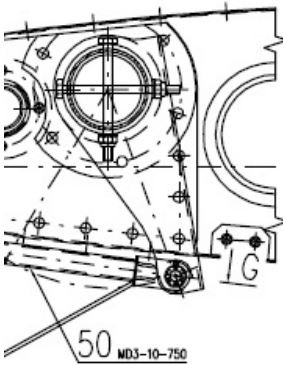
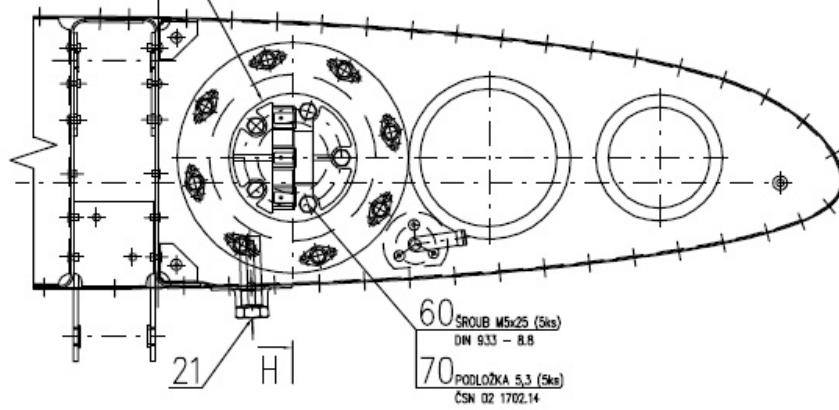
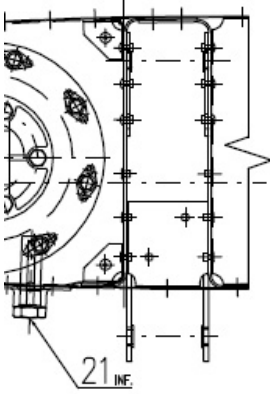

F - F
KRESLEN ZÁVĚS NA ŽEBRU 5 A B
ZÁVĚS NA ŽEBRU 2 JE Z.O.
(M 1 : 1)

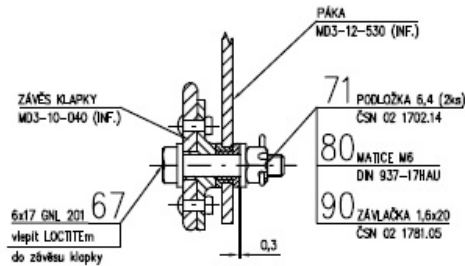

H - H
(M 1 : 2)

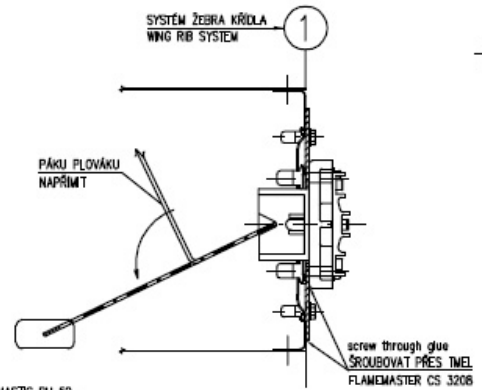

KŘÍDELKO NÝTOVAT PŘES TMEI ENFMASTIC PU 50.
ALEKON RIVETING THROUGH ENFMASTIC PU 50.



For further information, please contact Next Aircraft at E-mail airworthiness@next-aircraft.com